

PRENTICE

**2664 • 2764 • 2864
Site Prep Machines**



Built Better Than It Needs To Be

Prentice Site Prep Machines offer the ideal combination of powerful, proven hydraulics, exceptional balance and stability, and excellent maneuverability. A Quick-Attach connection system enhances the flexibility of the tractor by allowing quick and easy attachment changes, increasing the versatility of the machine and providing the flexibility to quickly change applications. The balanced center of gravity creates a stable platform for operating on uneven terrain. A rugged design ensures long hours of reliable operation, with ease of maintenance and low operating costs.



Quick-Tach

The Prentice Site Prep Machine's versatility is greatly enhanced with the addition of the optional Quick-Tach attachment coupling system. The Quick-Tach system is controlled from the cab and allows for quick, simple change from one attachment to the next. Quick couplers, properly sized for high flow attachments, are part of this system and provide quick hook-ups of multiple hydraulic circuits.

Work Tools

Prentice offers a choice of factory matched attachments to maximize machine productivity and flexibility including the Prentice Rotary Ax mower, Prentice Side Cut Felling Saw and the Prentice Stump Grinder. The "Quick-Flow" hydraulic system can also be harnessed to other powered attachments provided through your dealer including power brooms, snow blowers and rotary mulching heads such as those manufactured by Fecon®, Seppi®, and Tushogg®.

Full View Operator's Cab

The operator environment uses an ergonomic design that creates a comfortable work area with easy-to-use machine controls to reduce fatigue and increase efficiency and productivity.



Power Train

Cummins QSB 6.7L, Tier 3 compliant engines drive the Prentice Site Prep Machine through a rugged, field proven hydrostatic transmission providing maximum power and performance. Independent front and rear differential locks increase maneuverability and reduce tire slippage. A Flexaire® variable pitch, reversing engine fan is an option that helps keep the cooling system clean and help maintain proper operating temperatures.

Winch

The 2664, 2764 and 2864 Site Prep Machines are built with a winch ready rear frame. A two-speed, 88,965 N (20,000 lb.) capacity winch for self-recovery is provided as an option from the factory or as a field kit.

Hydraulics

The state-of-the-art closed center, variable displacement, pressure compensating hydraulic system provides power for braking, steering and attachment functions. The new Quik-Flow selection system allows the operators to quickly and easily install and operate a variety of attachments. The system automatically identifies the tool and dictates the flow from a dedicated variable hydraulic pump.

Engineered Durability

Prentice Site Prep Machines are built around a rugged, field proven center joint and engine house covers of heavy duty plates. The proven design provides full articulation for maximum maneuverability.



The Prentice engine house features angled panels to prevent debris from accumulating on the machine. Locking service covers provide quick and convenient access to the engine compartment. An optional bolt-on rear canopy is available.



The center joint features large, double tapered roller bearings to provide years of trouble-free service in the rugged conditions of day-to-day harvesting.



Rugged lift arms are constructed with a large torque tube and feature sealed pins and lift cylinders with cast ends for high durability.

Unprecedented View of the Work Area

The operator station on Prentice Site Prep Machines provides a wide-open, unobstructed view from the top to the ground and surrounding area. The unique design of the "reverse-slope" windshield prevents dirt and debris from accumulating in typical conditions.



Triple laminated Lexan windows and skylight provide protection for the operator. The oversized windows give the operator an unobstructed view of work area.



The engine housing is engineered with a sloped hood on each side to provide maximum rear visibility on both sides of the machine.

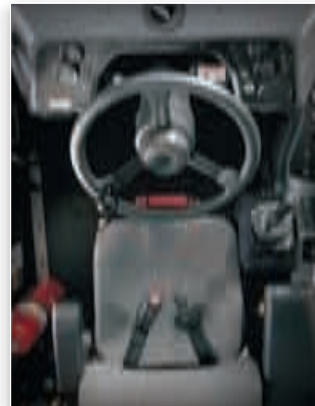

Operator comfort directly effects day-to-day productivity. Climate controlled Prentice operator stations maximize operator comfort while providing key features like "Quick-Steer" quarter-turn steering that dramatically improves cycle times while reducing fatigue.



Joystick steering controls are available as an option for operators that prefer this type of machine controls. The joystick control system features the same fast cycle times with smooth control of all steering operations.

Unobstructed Service Points

The tilting cab on Prentice Site Prep Machines provides unobstructed access to the hydraulic pumps and transmission. This dramatically reduces the amount of time required for routine maintenance while standing comfortably beside the machine.



A hand pump smoothly tilts the cab for quick, unobstructed maintenance.



Screen doors on each side of the machine protect the engine compartment while in operation. The screens can be quickly removed to gain unobstructed access to the engine compartment for routine maintenance.

2664/2764/2864 DIMENSIONS

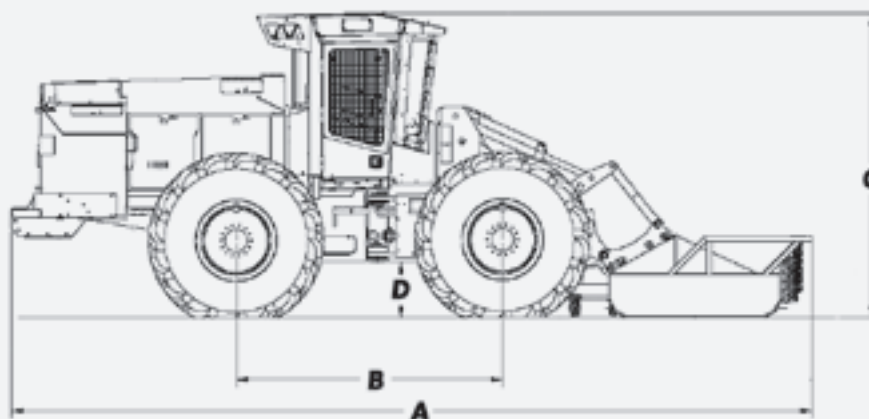

Dimensions	2664	2764	2864
A Overall Length with Prentice MR-244 attachment	780 cm (307")	858 cm (338")	858 cm (338")
B Wheelbase	258 cm (101.5")	287 cm (113")	287 cm (113")
C Overall Height	320 cm (126") ^a	320 cm (126") ^a	333 cm (131") ^b
D Ground Clearance	53 cm (21") ^a	53 cm (21") ^a	63 cm (25") ^b
• Overall Width	274 cm (107.9") ^a	292 cm (115") ^a	304 cm (119.8") ^b
• Turning Radius	455 cm (179")	503 cm (198")	527 cm (207.6")
• Weight, less attachment	12,020 Kg (26,500 Lbs) ¹	13,027 Kg (28,720 Lbs)	14,588 Kg (32,160 Lbs) ²
• Articulation Angle	84 degrees	90 degrees	90 degrees

^a with 28L x 26 tires

^b with 30.5 x 32 tires

¹ with Quik-Tach System

² with Quik-Tach system, winch, rear canopy, 30.5x32 tires



2664/2764/2864 SPECIFICATIONS

		2664	2764	2864
Engines				
Cummins QSB 6.7L, with Grid Air Heating and Charge Air Cooling, Tier 3 Compliant				
Rated Power @ 2200 RPM				
		142 kW (190 HP)	164 kW (220 HP)	194 kW (260 HP)
Flexaire variable pitch reversing fan				
		NA	OPT	OPT
Fuel Tank Capacity				
		272 L (72 Gal)	492 L (130 Gal)	492 L (130 Gal)
Electrical System				
12-volt system with circuit breaker protection and master disconnect, 145 Amp Alternator				
		STD	STD	STD
Lighting Package - 2 Forward, 2 Side, 2 Rear Facing, Mounted to Cab				
		OPT	OPT	OPT
Road Ready Package - includes Beacon light, horn, running lights, rear stop and tail lights, front and rear turn signals and side marker lights				
		OPT	OPT	OPT
Structural				
Tilt Over Operators' Cab				
		STD	STD	STD
Heavy Duty Engine House				
		STD	STD	STD
Bolt-on Rear Canopy				
		OPT	OPT	OPT
Wrap-around bumpers/Pressurized Water Tank				
		STD	STD	STD
Heavy Duty front and rear frames Long-life tapered roller bearing center joint, winch ready rear frame				
		STD	STD	STD
Drive Train				
Hydrostatic transmission with variable displacement pump and variable displacement motor. Two speed transfer case with manually operated shift/propel interlock; inboard planetary axles with front and rear hydraulic differential lock.				
		STD	STD	STD
Hydrostatic Pump				
		182 L/min @ 37,370 kpa 48 gpm @ 5420 psi	246L/min @ 37,370 kpa 65 gpm @ 5420 psi	246L/min @ 37,370 kpa 65 gpm @ 5420 psi
Filtration				
13 micron absolute rating		STD	STD	STD
Axles				
HA 2503		STD	STD	STD
HA 2513 (required for tire sizes over 67/34 x 25)		NA	OPT	OPT
Brakes				
Service brake--hydrostatic-dynamic braking, plus pedal operated, wet disc brakes on front axle		STD	STD	STD
Parking brake--lever operated, cable actuated with caliper disc on drive line at transfer case		STD	STD	STD
Travel Speeds				
Low Range w/ 28L x 26 Tires		8 km/H (0-5 MPH)	8 km/H (0-5 MPH)	8 km/H (0-5 MPH)
High Range w/28L x 26 Tires		24 km/H (0-15 MPH)	24 km/H (0-15 MPH)	24 km/H (0-15 MPH)
Tires				
28 L x 26 14 PR		STD	STD	STD
30.5 x 32 16 PR		NA	OPT	OPT
67 x 34 X 25 14 PR		OPT	OPT	OPT
Tire Seal				
Installed in all four tires		OPT	OPT	OPT
Hydraulic System				
Pumps				
Load sensing, variable displacement pumps for lift and tilt, attachment and steering, double gear pilot/differential lock & circulation pump		STD	STD	STD
Auxiliary Hydraulics - "Quick-Flow" Variable electronic controlled pump flow up to--		242 L/min @ 34,991 kpa 64 GPM @ 5075 psi	242 L/min @ 34,991 kpa 64 GPM @ 5075 psi	318 L/min @ 34,991 kpa 84 GPM @ 5075 psi
Cylinders				
Steering (bore x rod)		9 cm x 5 cm (3.5" x 2.0")	9 cm x 5 cm (3.5" x 2.0")	9 cm x 5 cm (3.5" x 2.0")
Lift (bore x rod)		10 cm x 6 cm (4.0" x 2.5")	10 cm x 6 cm (4.0" x 2.5")	10 cm x 6 cm (4.0" x 2.5")
Tilt (bore x rod)		9 cm x 5 cm (3.5" X 2.0")	10 cm x 6 cm (4.0" x 2.5")	10 cm x 6 cm (4.0" x 2.5")
Filtration				
Main Return - 4.5 Micron absolute rating		STD	STD	STD
Auxiliary Hydraulics - 13 micron absolute rating		STD	STD	STD
Prentice Quik-Tach attachment coupler system				
		OPT	OPT	OPT
Hydraulic Winch, two-speed, free spooling, 88,965 N (9072 kg) (20,000 lb) capacity				
		OPT	OPT	OPT
Hydraulic Tank Fill				
Machine mounted, hand operated		STD	STD	STD
Machine mounted, electrically operated		OPT	OPT	OPT
Cab And Controls				
High visibility operators cab, Flat three-piece laminated reverse slope LEXAN windshield, eyebrow skylight, left side entry door, recessed door latch, sliding windows, right side emergency exit, high back operator's seat, electronic gauges and warning lights, air conditioning/heating system digital AM/FM cassette stereo, horn, 10lb. fire extinguisher, water tank hose storage, dual 12V power points				
		STD	STD	STD
Power Tilt Cab with Hand Pump				
		STD	STD	STD
Right Hand Joystick Lift and Tilt Control				
		STD	STD	STD
1/4 Turn "Quick Steer" with Steering Wheel, Foot Pedal Auxiliary Control, Lap belt				
		STD	STD	STD
Joystick Steering with Foot Pedal Auxiliary Control, four-point seat belt				
		OPT	OPT	OPT
Joystick Steering with Joystick Button Auxiliary Control, four-point seat belt				
		OPT	OPT	OPT
Back-up Alarm				
		STD	STD	STD



www.prenticeforestry.com

Blount Inc.
535 Mack Todd Road
Zebulon, NC 27597
919-269-7421

We reserve the right to change specifications and to improve our products without notice or obligation.

Form No. PRSPM-0207 · Printed in U.S.A.